



Factory
FACTORY HEAD OFFICE - WAREHOUSE -
WORKSHOP FACTORY Kayseri City,
Organize OSB, NO:21

By EFTCG
NORDIC
C E | L I N G

BAFFLE CEILING

Wood Colors



Bamboo Wood Texture



Oak Wood Texture



Walnut Wood Texture



Dark Walnut Wood Texture

System Description

Extruded Baffle system is an alternative and durable linear ceiling system constructed from extruded U profiles suspended to a basic hook-on ceiling suspension system. The baffle design allows the air circulation in the room through the ceiling void. This is also useful for smoke extraction when this is the case. U Baffle system is hung onto the main runner profiles, those are suspended from the soffit at 1200mm centres.

System Features

- U baffles are available in 20-50mm width, height 100mm
- Available in 3000mm lengths, splicers can be used for longer plans
- Minimum 25-year product life

Finish - Yüzeý Bitiş

Baffle profiles are offered with polyester powder coating process supplied as standard with RAL9010 white color; or also available with wooden finish, or even special anti-bacterial coatings

Grid System - Taşıyıcı Sistem

Galvanized steel Z and L profiles, RAL 9005 black.

Shape - Şekil

U shaped extruded aluminium baffles. Can be installed at as requested, standard is 50, 100 or 150mm centres.

Perforation

n/a

Weight

Approximately 6kg/m² for 20mm width and 100mm height; installed at 100mm c/c.

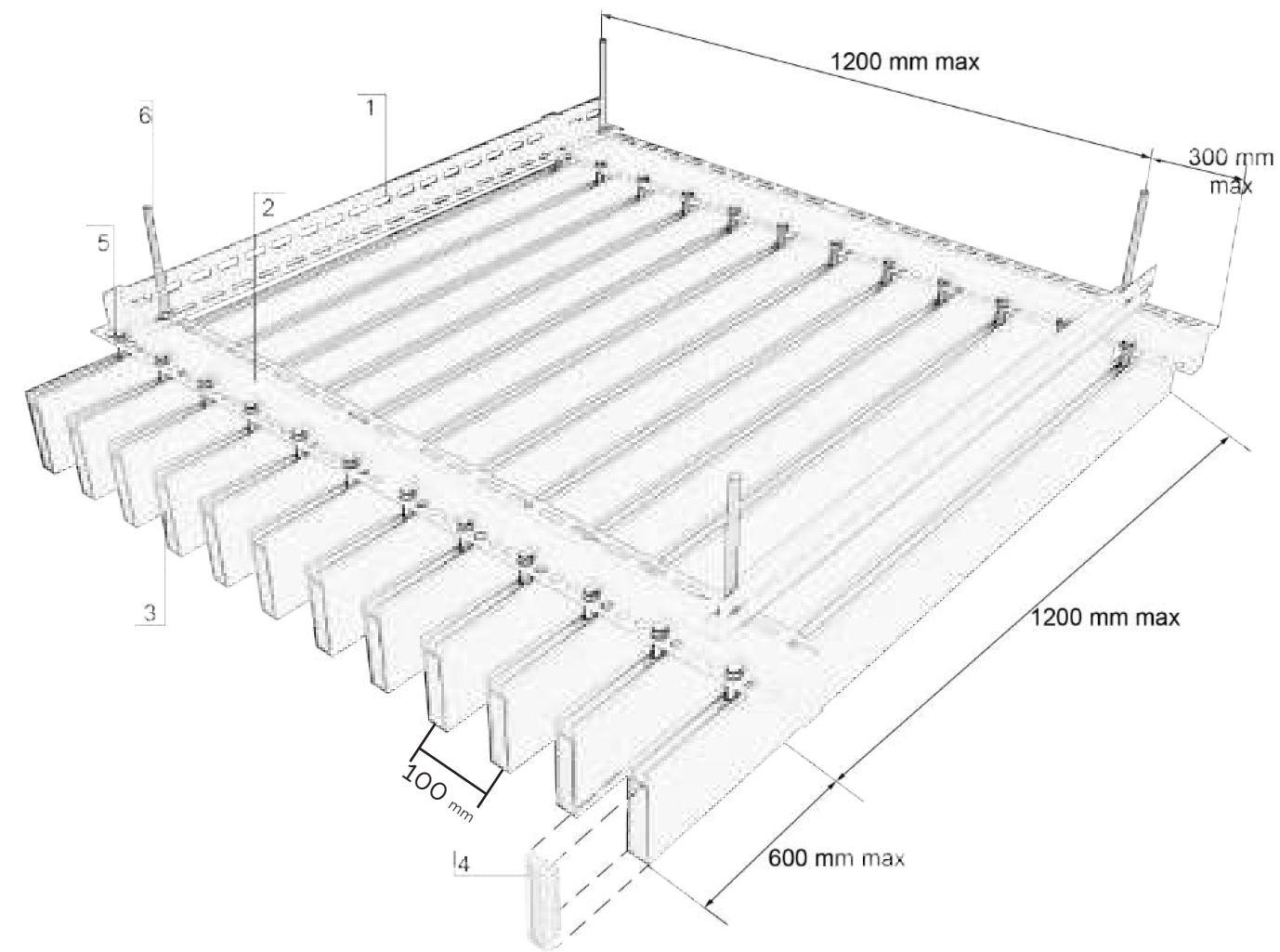

1- L Profil 2- Z Profil 3-Baffle 4- Cap 5- Bolt, Nut, Washer 6-Hanger Rod

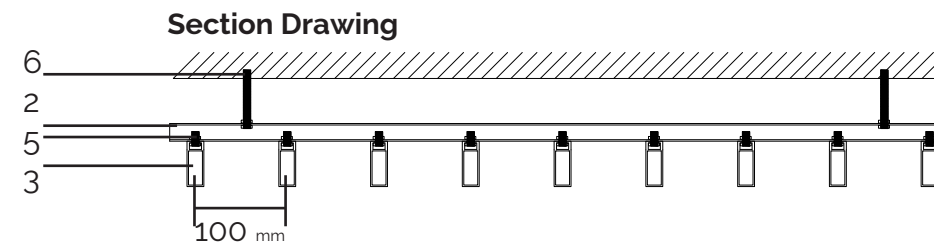

Baffle System Components	Item Number	Item Description	Length	Tube Distance	Weight (kg)
		Hanger Rod 100cm, M6		all	0,20 kg / pcs
		Fixing Dowel, M6		all	0,05 kg / pcs
		Baffle Main Runner Z, (RAL 9005)	3000mm	all	0,76 kg / pcs
		Baffle Main Runner L, (RAL 9005)	3000mm	all	0,64 kg / pcs
		Bolt M6x16/Nut M6/Washer M6		all	0,03 kg / pcs
		20mm width Baffle (RAL 9010)	3000mm	all	0,30 kg / pcs
		40mm Width Baffle (RAL 9010)	3000mm	all	0,60 kg / pcs
		20mm Baffle Splice		all	0,03 kg / pcs
		40mm Baffle Splice		all	0,06 kg / pcs